

**Liquid metal handling  
from a single source**



## Flexible handling of casting capacities

For more than 20 years Bartz has developed and designed furnaces, casting and stacking stations, granulation stations and transport crucibles. The major focus here is on the development and implementation of concepts for complete smelting plants and the handling of liquid aluminium from the smelting plant to the foundry. Melting, transporting, holding and casting – all under one roof.

Energy and material costs are decisive factors for the competitiveness of foundries. Advantages can be gained particularly through the delivery of liquid aluminium, where foundries can adapt their casting capacities quickly and effectively to the current requirements without having to hold furnace systems available.

In addition to this the handling and storage costs are noticeably reduced for just-in-time deliveries. The environment also benefits from this concept: as no re-melting is necessary, not just considerable amounts of energy are saved, but especially emissions are also greatly reduced.

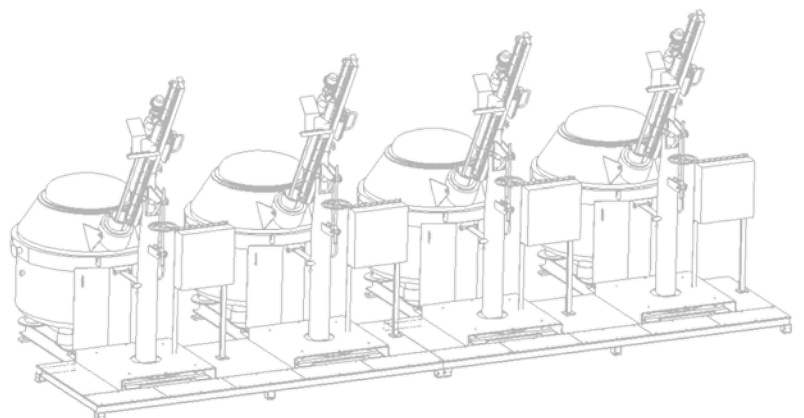



## All components under one roof

For this Bartz supplies all the necessary plant components in “Made in Germany” quality. It goes without saying that all items – from those used for filling the transport crucibles to those used for transferring the liquid aluminium to the appropriate casting plants – are carefully matched and are adaptable to the respective operating conditions.

Bartz’s service does not end with supply and assembly of the plant components. As Bartz is a system supplier, all project work right up to customer acceptance and production monitoring is carried out by the company’s own staff, ensuring both smooth functioning and successful commissioning of all plant components.



### Components

- Road transport crucibles
- Crucible heating stations
- Gas-heated holding stations
- Stationary and mobile tilting stations
- Crucible hot cleaning stations
- Impeller stations
- Container turning devices
- Crane traverses



## Contact

**Bartz Maschinenbau GmbH**  
Robert-Bosch-Straße 14 + 18  
56727 Mayen  
Germany

Tel.: +49 2651 49 30 - 0  
Fax: +49 2651 48 75 8  
info@bartz-maschinenbau.de  
www.bartz-maschinenbau.de

